

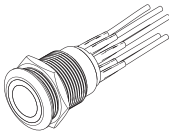

PB19VB_BBL - PB19VB_BBL-E

	COMPOSITION DES KITS / BILL OF MATERIAL			
				
	PB19GW	PBP19_4	PBP19_B	PCB0070
PB19VB_SP	1 x	/	/	1 x
PB19VB_BBL	1 x	/	1 x	1 x
PB19VB_BBL-E	1 x	1 x	/	1 x
PB19VB_BBL-LE	1 x	1 x	1 x	1 x

CARACTÉRISTIQUES TECHNIQUES - TECHNICAL SPECIFICATIONS

Caractéristiques générales - General specifications	
Tension d'alimentation / Operating voltage : 12 - 24V AC/DC +/- 10%	
Consommation / Consumption : max. 60 mA	
Pouvoir de coupure du contact inverseur par relais (C/NO/NC) : 30V DC - 2A / 125V AC - 0,5A Switching capacity of the changeover contact by relay (C/NO/NC) : 30V DC - 2A / 125V AC - 0,5A	
Pouvoir de coupure du contact (NC/NC) : 30V DC - 2A Switching capacity of the contact (NC/NC) : 30V DC - 2A	
Couleur de la LED au repos / LED colour at resting state : Blanc / White Couleur de la LED à l'état commuté / LED colour at switched state : Vert / Green	
Réglage de la temporisation / Settings of the timer : 0 - 60 s	
Réglage du buzzer / Settings of the buzzer : 70 dB - 35 dB - OFF	
Réglage de l'intensité lumineuse / Adjustements of light intensity : 100% - 50%	
Diamètre de filetage / Thread diameter : Ø 19 mm	
Longueur des fils / Wire length : 15 cm	
Connexion / Connection : Connecteur JST - JST Connector	
Indice de protection / IP rating : IP 20	
Température de fonctionnement / Operating temperature : 0 + 40°C	
Poids / Weight (PB19VB_SP) : 0,0385 kg Poids / Weight (PB19VB_BBL) : 0,10 kg	
Poids / Weight (PB19VB_BBL-E) : 0,07 kg Poids / Weight (PB19VB_BBL-LE) : 0,13 kg	

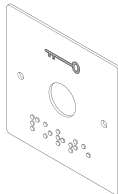
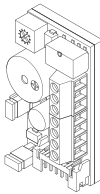
MONTAGE - MOUNTING

Pose encastrée - Mortise mounting

PB19VB_BBL-E

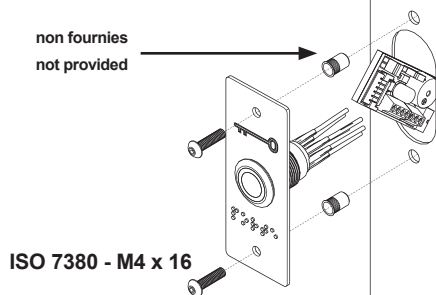

Pose avec pot d'encastrement Mounting with flush-box

PB19VB_BBL

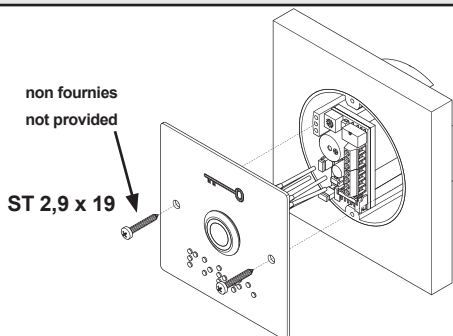

Pose encastrée possible sur pot de 60 mm standard (non fourni - profondeur préconisée = 50 mm)
Mortise mounting possible with standard 60 mm outlet box (not provided - recommended depth = 50 mm)

Boîtiers de montage en applique (EN OPTION) - Surface mounting housing (OPTIONAL)

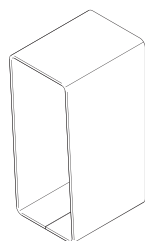

PBH1

Pour modèles PB19_BBL-E / PB19_BBL-LE
For models PB19_BBL-E / PB19_BBL-LE

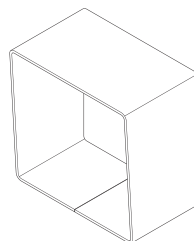

PBH2

Pour modèles PB19_BBL / PB19_BBL-LE
For models PB19_BBL / PB19_BBL-LE

DIMENSIONS

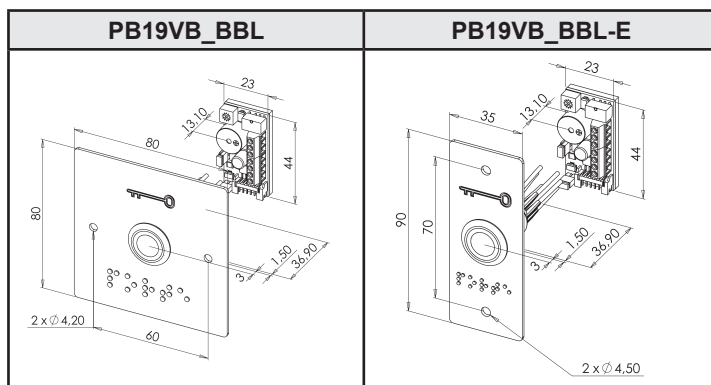

RACCORDEMENT - CONNECTION

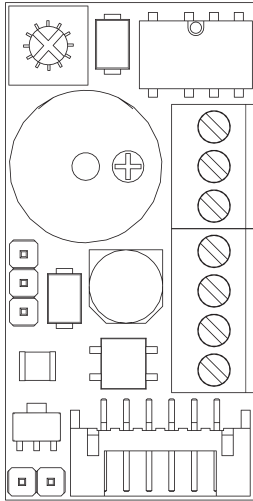

Section des conducteurs :
Conductor's cross-section :

max. 1 mm²

C } Relais Contact sec du relais temporisé géré par l'électronique
NO } Relay Dry contact of the time setting relay (controlled by the electronic)
NC }
NC } Contact sec mécanique du bouton poussoir
NC } Push button mechanical dry contact
- } 12-24 V AC/DC
+ }

REGLAGES - SETTINGS

Réglages de la temporisation - Settings of the timer

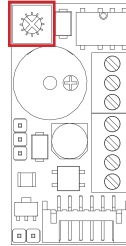
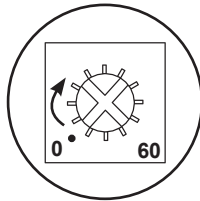

Réglages du buzzer - Settings of the buzzer

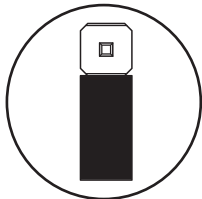

ON (70 dB)

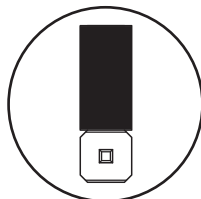

ON (35 dB)

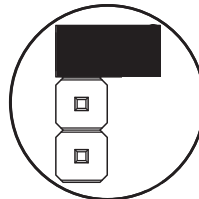

OFF

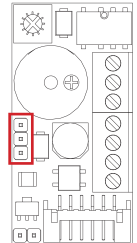

Réglages de l'intensité lumineuse - Adjustments of light intensity

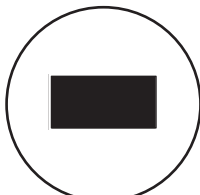

100%

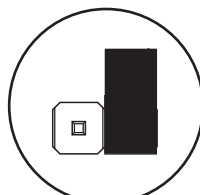

50%

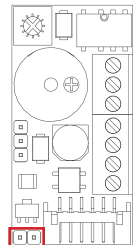

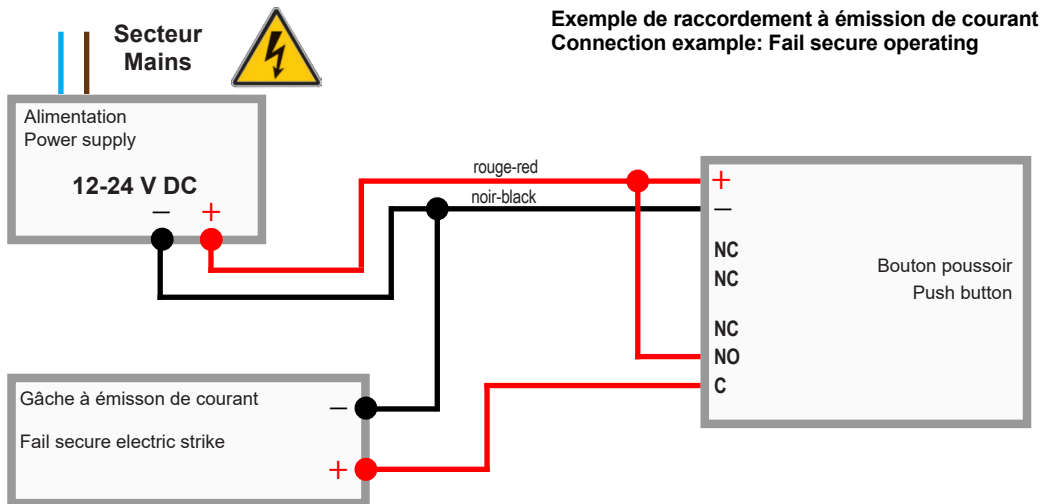

Exemple de raccordement à émission de courant
Connection example: Fail secure operating

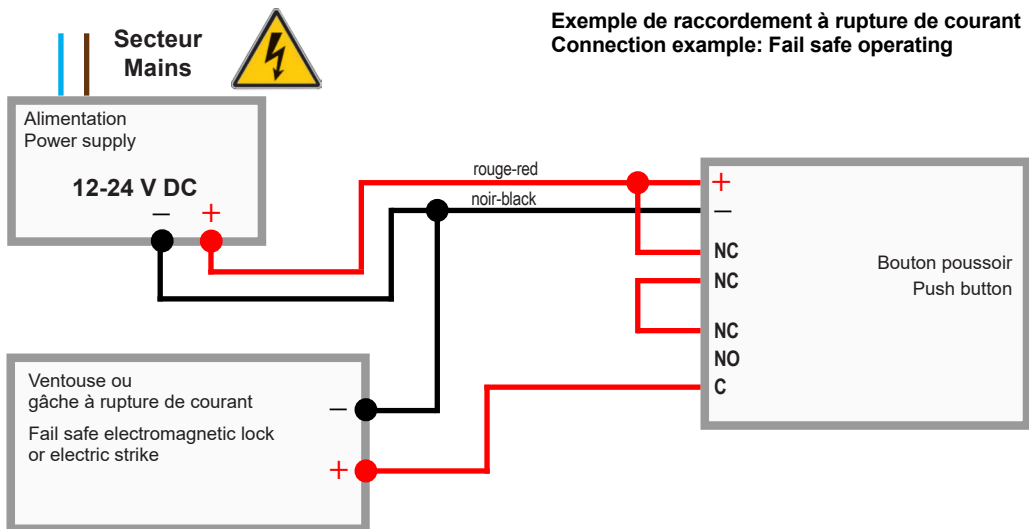

Exemple de raccordement à rupture de courant
Connection example: Fail safe operating

⚠ Attention - Caution

- Utiliser une tension conforme à celle indiquée.
L'utilisation d'une tension inappropriée n'est pas couverte par la garantie et peut causer des dommages irréversibles au produit.
- Use correct input voltage as specified.
Wrong input voltage may damage the product. This failure is not covered by the product warranty.

